

ESTES PARK SANITATION DISTRICT

COLLECTION LINES

RULES AND REGULATIONS



Updated 11/13/07

## TABLE OF CONTENTS

<u>SECTION</u>	<u>TITLE</u>	<u>PAGE</u>
1.00	<u>INTRODUCTION</u>	
1.10	Disclaimer	5
1.20	Purpose and Scope of Policies	5
2.00	<u>DEFINITIONS</u>	
2.10	District	6
2.20	Directors	7
2.30	Collection Lines	7
2.40	Professional Organizations	7
3.00	<u>AGREEMENTS AND POLICIES</u>	
3.10	Permit to Install or Modify Sewer	8
3.20	User Fees	8
3.30	Easements	9
3.40	Deeding Mains	9
3.50	Requirement Reviews	9
3.60	Shared Service Line Agreements	9
3.70	Sewer Line Locations	10
4.00	<u>REQUIREMENTS OF ACCEPTABLE INSTALLERS</u>	
4.10	Occupation License	11
4.20	Insurance Requirements	11
4.30	Safety Measures	12
4.40	Sewer Line Installation by Property Owner	13

5.00	<u>UNLAWFUL CONNECTS</u>	
5.10	Dangerous Compounds	13
5.20	Non-Wastewater Introduction	13
6.00	<u>CONSTRUCTION REQUIRMENTS - SERVICES</u>	
6.10	Pipe	14
6.20	Water and Sewer Line	14
6.30	Pipe Installation	15
6.40	Depth of Line	16
6.50	Clean outs	16
6.60	Tap Preparation	16
6.70	Tap Connection	17
6.80	Sewer Line Inspections	17
6.90	Abandoned Lines	17
7.00	<u>CONSTRUCTION REQUIREMENTS - MAIN LINES</u>	
7.10	Pipe	18
7.20	Utility Separation	18
7.30	Pipe Installation	19
7.40	Depth of Line	20
7.50	Manholes	20
7.60	Stub outs	21
7.70	Required Inspections	22
7.80	Construction Guarantee	23
7.90	Documentation	23
8.00	<u>MAINTENANCE REQUIREMENTS</u>	
8.10	Sewer Service Lines	24
8.20	Sewer Main Lines	24

9.00	<u>SPECIAL APPLICATIONS AND REVIEWS</u>	
9.10	Board of Directors Comments	25
9.20	Interceptors	26
9.30	Non-Gravity Flow Applications	27
9.40	Pre-Treatment	28
10.00	<u>COMPLIANCE</u>	
10.10	Failure to Follow Regulations	28
10.20	Abandoned Taps	28
11.00	<u>EXHIBITS</u>	29

# ESTES PARK SANITATION DISTRICT

## COLLECTION LINES

### RULES AND REGULATIONS

#### 1.00 INTRODUCTION

#### 1.10 Disclaimer

#### IMPORTANT

The requirements and procedures contained in these rules and regulations do not represent a contract, nor should they be relied upon as binding or inflexible. The District reserves the right to change or rescind these rules and regulations at any time, as well as the right to determine their meaning, purpose and effect. The District also reserves the right, in its sole discretion, to determine whether, and to what extent, these rules, regulations and procedures should be applied in any given circumstances.

#### 1.20 Purpose and Scope of Policies

These rules and regulations for the installation of wastewater collection lines, within the boundaries of the Estes Park Sanitation District, are hereby established in the public interest. Properly installed and maintained collection lines will serve many purposes.

First, they protect the public health and environment from harm that could occur from lines that experience ex-filtration, leaking lines or lines that backup periodi-

cally. Second, they save our constituents financial resources. Properly installed service lines or main lines require a minimum of maintenance. They also prevent infiltration of groundwater or rainwater into the District's collection system. This prevention saves costs associated with treatment and capital expenses that would be required to treat greater capacity.

Any party found to be in violation of the rules and regulations of the District shall be provided written notice stating the nature of the violation and will be provided a reasonable time limit for satisfactory correction of the violation. Any party still in violation of the District's rules and regulations, after the time limit of the written notice has expired, shall be subject to further action by the District. This action shall include, but not be limited to: Department of Health notification, District correction of the problem, financial penalties or an increase in the user fee rate, discontinuance of service, or proper legal channels. Any costs associated with the District correction of the problem or discontinuance of service will be identified and shall be the liability of the violating party. Failure to pay these charges, within a reasonable time period will result in the discontinuance of service. A reasonable time period in this instance shall be 30 days, unless otherwise approved by the Board of Directors.

## 2.00 DEFINITIONS

Unless otherwise stated, the meaning of the terms used in these rules and regulations shall be as follows:

### 2.10 District

Shall mean the Estes Park Sanitation District or duly selected representatives of the District authorized to conduct business for the District and/ or administer the provisions of these rules and regulations.

2.20 Directors

Duly elected officials of the District.

2.30 Collection Lines

2.31 Sewer Service Lines

Shall be a wastewater line owned and maintained by a private party. In most instances, this shall be the owner of the property or the tap holder of the property, producing the wastewater. The service line shall begin at a point immediately outside the building it services and end at the point where it connects to the District's main sewer line. The service line shall include the fitting that is used to join to the District's main.

2.32 Sewer Main Line

Also referred to as a trunk line or collection main. This is a wastewater line whose primary purpose is the collection of wastewater from private service lines and the transportation of this flow to the District's treatment facility. This line is owned and maintained by the District. District ownership of these lines shall begin and end at a manhole.

2.40 Professional Organizations and Publications

2.41 IAPMO

International Assoc. of Plumbing and Mechanical Officials.

2.42 IPC

International Plumbing Code, as published by the IAPMO, in the most current edition. The rules established by the International Plumbing Code shall apply to all situations not addressed by these rules and regulations or by the Board of Directors of the District.

- 2.43            ASTM  
                  American Society for Testing and Materials (current edition)

3.00            AGREEMENTS AND POLICIES

3.10            Permit to Install or Modify Sewer Service

Prior to any building construction or remodel of existing buildings, the party seeking permission to build or remodel, shall apply for a Permit to Install or Modify Sewer Service. Normally, a building permit from the Town of Estes Park is required for such improvements and an authorized signature from the District on a routing slip is required before a building permit will be issued. Prior to being issued the Permit to Install or Modify Sewer Service, the owner of the property or their representative will need to:

- state the location where service is requested;
- inform the District of the proposed use for the property (residential or commercial);
- provide building plans or remodel plans identifying sewer producing fixtures;
- provide details of the sewer line that will service the property;
- provide the name of the party who will do the sewer line installation;
- pay all System Investment Fees, as per District schedule. Once the permit is issued, construction can occur, under terms of the permit.

3.20            User Fees

User fees are required of all properties using the Districts treatment facilities. Full user fees will begin once the tap has been made and any plumbing fixtures are in place. A minimum user fee will be in place until the point when full user fees are assessed.

### 3.30 Easements

Easements may be required between private parties or for use by the District. Private easements must be signed and in the office of the District prior to beginning excavation and installation of sewer service lines (see Exhibit 3.30A). Easements for main sewer lines that will be owned and maintained by the District, as per agreements with developers must be made part of the official recorded plat or through a signed easement agreement, with the actual location of the line through the property included in the agreement. This process must be complete prior to allowing units to tap to the collection system.

### 3.40 Deeding Mains

The District will accept lines that meet the standards and requirements of District main sewer lines. This includes construction standards, easements and acceptance by the Board of Directors. Quit claim or warranty deeds must include an exhibit or physical description of the line to be assumed for ownership by the District.

### 3.50 Requirement Reviews

The Board of Directors will review plans for development that include sewer line installations. As part of the review, the Directors may include special requirements of the development to insure that the best interests of the District are served. These requirements will be need to be met before any units are allowed to tap to the collection system.

### 3.60 Shared Service Line Agreements

Shared service line agreements are agreements between private parties that consent to share a service line that connects to the Districts main line. The Board of Directors must approve shared service agreements. All service line agreements must include a

description of the line, its physical location and obligations regarding ownership and maintenance. All parties involved must sign the agreement. All provisions of the instrument, including the benefits and burdens, run with the land and are binding upon the heirs, assigns, successors, tenants and personal representatives of the parties. The agreement must be recorded (see Exhibit 3.60A).

Shared service lines between pressure service lines and gravity service lines are not allowed unless both lines belong to one owner on one parcel of property.

### 3.70 Sewer Line Locations

As part of the services performed by the District, the District agrees to perform locates for sewer main lines and service lines.

#### 3.71 Sewer Main Line Locations

Sewer main lines will be located for requesting parties, with 24-hour notice requirement. Emergency locates will be performed on an as needed basis. The District will guarantee locates within 18 inches, for a period of 30 days. Requests for locates on the same property by the original requesting party within 60 days of the original locate, may be billed charges as per District schedule.

#### 3.72 Sewer Service Line Locates

As a service to their customers, the District will provide a courtesy locate for sewer service laterals when their location is known. In instances where the location of a service line is not known, the District will notify the requesting party and the homeowner that the exact location of the line is unknown. The excavating company will be asked to open cut the trench carefully. Should the service line be broken during excavation, they will be instructed to call at once so a courtesy repair to line can be made. To get a more accurate location of the line, a plumbing snake can be inserted into the line through a clean out or

through a drain in the home. District personnel will then attempt to locate the line with a metal detector. It shall be the building owner's responsibility to have the sewer snake inserted into the line.

Some excavating companies will use technologies that do not employ open cut trenches, such as boring. The District does not encourage these methods because sewer service lines can be broken without any knowledge of the break until problems occur in the buildings drain lines, such as backups.

The District shall not accept any liability for service lateral locates. The sewer service laterals are the responsibility of the building owner.

#### 4.00            REQUIREMENTS OF ACCEPTIBLE SEWER LINE INSTALLERS

The following will be required of all parties who contract with the District to install sewer main lines or contract with private parties to install sewer main lines or sewer service lines within the boundaries of the District.

#### 4.10            Occupation License

All contractors, excavation companies, plumbers and other entities, who install sewer lines within the boundaries of the District, will be required to have occupation licenses from the Town of Estes Park.

#### 4.20            Insurance Requirements

All contractors, excavation companies, plumbers and other entities, who install sewer lines within the boundaries of the District, will be required to carry the following types of insurance with these minimum limitations:

#### 4.21            General Liability

General liability limits of \$600,000 combined or \$300,000 per person and \$300,000 per occurrence for bodily injury and property damage.

4.22 Auto Liability

Auto liability limits of \$600,000 combined or \$300,000 per person and \$300,000 per occurrence for bodily injury and property damage.

4.23 Workman's Compensation

Workman's compensation insurance is required for all contractors. All subcontractors shall be required to have workman's compensation insurance or be covered by the general contractor's policy. All contractors declaring Independent Contractor Status shall be required to file a Declaration of Independent Contractor Status form with the District office prior to any work being performed. The minimum coverage's for workman's compensation insurance is \$100,000 each accident. Policy disease limits of \$500,000 with \$100,000 per person are also required. Contractors must submit proof of insurance documents to Estes Park Sanitation District office prior to any excavation work being performed.

4.30 Safety Measures

All Acceptable Sewer Line Installers shall perform sewer line installations in a safe manner. Slope requirements for trench walls shall be followed. In instances where unstable trench walls create unsafe working environments, adequate shoring or trench boxes will be required. All excavations for sewer lines shall be adequately guarded with barricades and/ or other safety equipment. It shall be the contractors' responsibility to make sure they comply with the rules and regulations regarding safety measures of the Estes Park Sanitation District, Town of Estes Park, Larimer County, State of Colorado Department of Transportation and the United States Federal Government (OSHA).

4.40 Sewer Line Installation By Property Owner

Sewer line installations, performed by the property owner, will be subject to the same rules and regulations as private contractors (including inspections). However, should sewer line excavation occur only in the area inside the individuals property, the insurance requirements will be waived.

5.00            UNLAWFUL CONNECTS

5.10            Dangerous Compounds

It shall be unlawful for any individual or enterprise to deposit by any means whatsoever, into any plumbing fixture, floor drain, interceptor, sump or device connected to the collection system of the District, any ashes, cinders, solids, rags, flammable, poisonous or explosive liquids or gases, oils grease and any other thing whatsoever which would, or could cause damage to the Districts wastewater treatment and collection facilities. Any individual or enterprise that violates these conditions shall be subject to fines or penalties as determined by the Board of Directors of the Estes Park Sanitation District. Notice of the violation may also be submitted to the Colorado Department of Health and/or the Environmental Protection Agency.

5.20            Non-wastewater Introduction

No rain, surface or subsurface water shall be connected to or discharged into any drainage system that connects to the Districts collection facilities. No cess-pool, septic tank, seepage pit or drain field shall be connected to any drainage system that connects to the Districts collection facilities.

6.00            CONSTRUCTION REQUIREMENTS - SEWER SERVICE LINES

6.10            Pipe

Pipe materials approved by the District for use in constructing sewer service lines are:

- Ductile Iron Pipe - ASTM specifications (A536) or equal
- PVC Plastic Pipe - ASTM specifications (D3034, SDR 35) with gasketed water tight joints. Other materials must be pre-approved by the District.
- The minimum size of any building sewer shall be determined on the basis of the total number of fixture units drained by the building or property. Minimum allowable pipe size will be four (4) inch. Six (6) inch PVC will be required when more than four multi family units share a common service line. Eight (8) PVC will be required when more than ten multi-family units connect to a common service line. Commercial establishments will be reviewed on a case by case basis.

#### 6.20 Water and Sewer Line Separation

Water and sewer lines shall maintain a ten (10) foot minimum parallel separation. Where depth allows, when water and sewer line cross, water lines shall cross above sanitary sewer lines and shall be constructed to provide a separation of at least twelve (12) inches between the bottom of the water line and the top of the sewer line. When the above conditions cannot be met, one of the following conditions shall apply:

- sewer lines shall be constructed of pipe material with joints equivalent to the standards used for the construction of water mains. Pressure testing will be required before back filling is allowed.
- a twenty (20) foot continuous piece of Schedule 35 (SDR 35) PVC pipe or equivalent, may be used as a sleeve for the sanitary sewer line. The pipe shall be centered at the point of crossing so that the joints will be equidistant and as far as possible from the water line.

The sleeve shall be a diameter large enough to handle the size of sewer pipe required by the District for the transmission of wastewater.

- sewer lines will be encased in concrete for ten feet on each side of the water line. A minimum of six inches of concrete surrounding the sewer pipe will be required.
- in all instances the water line shall not come in contact with the sewer line. Also, adequate support shall be provided to prevent excess deflection of all piping materials.

### 6.30 Pipe Installation

Service line installation and the back filling of the trench shall be performed in accordance with ASTM specifications.

- All joints and connections shall be watertight, gasket, bell and spigot, with elastomeric type gaskets. Glue joints will not be allowed. Rubber couplings shall be molded, one piece, neoprene with stainless steel bands (FERNCO Type 1056 or equivalent). Caulder or Caulder type, couplings will not be allowed.
- A continuous section of 14 gauge coated electrical wire shall be included in the trench with the sewer pipe in order to provide for quick and accurate line locates. The wire shall be provided at the District's expense and shall be inspected prior to back filling the trench.
- Bedding for the pipe shall be comprised of suitable material, with no larger than two (2) inch smooth rock. The pipe will be covered with at least twelve (12) inches of the same suitable material. The balance of the trench can be filled with other suitable material.
- Minimum slope requirements allowable for four (4) and six (6) inch sewer service lines will be  $\frac{1}{4}$  inch per linear foot of pipe.
- All excavations and trench work shall include adequate clean up of the grounds that have been disturbed. If an installer is working through an

existing easement of the Districts, the disturbed area shall be returned to its approximate state, previous to the excavation. This may include, but not be limited to: raking, reseeding, special ground cover (washed rock, road base, etc.) or re-paving.

#### 6.40 Depth of Line

Minimum depth of bury for a sanitary sewer service line shall be thirty-six (36) inches, where practical except from approval by the District. If possible, depth of buries of forty-eight (48) inches or greater are recommended.

#### 6.50 Clean outs

Within five (5) feet of the building, a double sewer clean out shall be installed outside the building at the lower end of the building drain and extended to grade. Additional sewer clean outs shall be installed at intervals not to exceed one hundred (100) feet in straight runs and for each aggregate change in direction exceeding one hundred and thirty five (135) degrees. These clean outs shall be double clean outs or clean outs installed with a wye branch to allow access in both directions of the pipe. All clean outs located in driveways, patios or other concrete/ asphalt areas will be required to install slip tops to prevent them from breaking and to allow for access.

#### 6.60 Tap Preparation

When possible, taps shall be made in the Districts mains lines with wyes. Where wyes are not available, a representative of the District shall make taps. The owner or contractor in charge of installing the service line shall carefully expose the sanitary sewer main and remove all soil, gravel, fill dirt, etc. from around and under the sewer main to enable District representatives to perform the tapping operation. Should the District representative determine that unsafe trench walls are present, the owner or

contractor will be required to take all steps necessary to provide for the safety of the District personnel. See Exhibits Section for diagram.

#### 6.70 Tap Connection

Only representative of the District shall perform tapping of District main lines. Twenty-four (24) hour notice is required to perform the tap. Taps will not be done on weekends (Saturday or Sunday) or on holidays observed by the District.

#### 6.80 Sewer Line Inspections

A final inspection of the service line is required prior to the owner or contractor back filling over the line. The inspection will be visual and tests may be made by the District representative to determine the integrity of the line installation. Back filling over the line will not be allowed until the line passes the inspection of the representative. Twenty-four (24) hour notice is required to perform the inspection. Inspections will not be done on weekends (Saturday or Sunday) or on holidays observed by the District.

#### 6.90 Abandoned Lines

Lines may be classified as abandoned, due to removal of the building it services or the replacement of the line by another line. In all instances, abandoned lines must be plugged or closed by District personnel to prevent infiltration into the Districts collection system. All owners or contractors will be required to contact the District in situations where a service line is to be abandoned. Failure to do so may result in actions taken by the District that may involve financial consequences to the responsible party or parties.

### 7.00 CONSTRUCTION REQUIREMENTS - SEWER MAIN LINES

The District agrees to accept for ownership and maintenance, sewer main lines installed by acceptable installers that meet all of the following requirements established in Section 7 by the District. The District will not accept ownership of any line less than eight (8) inches in diameter. District ownership of the line shall begin and end at a manhole.

#### 7.10 Pipe

Pipe materials approved by the District for use in constructing sewer service lines are:

- Ductile Iron Pipe - ASTM specifications (A536) or equal
- PVC Plastic Pipe - ASTM specifications (D3034, SDR 35) with gasketed water tight joints, or other suitable materials approved by the District.
- The minimum size of any sewer main shall be eight (8) inches in diameter. Larger sizes of pipe may be required, as determined by the Directors of the District.

#### 7.20 Utilities Separation - Water, Sewer and Other Utilities

Water and sewer lines shall maintain a ten (10) foot minimum parallel separation. When water lines cross above sanitary sewer lines, they shall be constructed to provide a separation of at least twelve (12) inches between the bottom of the water line and the top of the sewer line. When conditions physically prevent a vertical separation of twelve (12) inches, one of the following conditions shall apply:

- the sewer line shall be constructed of pipe material with joints that are equivalent to the standards used for the construction of water mains. Pressure testing will be required before back filling is allowed.

- a twenty (20) foot continuous piece of Schedule 35 (SDR 35) PVC pipe or equivalent, may be used as a sleeve for the sanitary sewer line. The pipe shall be centered at the point of crossing so that the joints will be equidistant and as far as possible from the water line.
- the sewer line will be encased in concrete for ten feet on each side of the water line. A minimum of six inches of concrete surrounding the sewer pipe will be required.
- in all instances the water line shall not come in contact with the sewer line. Also, adequate support shall be provided to prevent excess deflection of all piping materials.
- all other utility lines (electric, gas, telephone, cable, and storm drains) shall maintain a five (5) foot minimum parallel separation.

### 7.30 Pipe Installation

Sewer Main Line installation and the back filling of the trench shall be performed in accordance with ASTM specifications.

- all joints and connections shall be watertight, gasket, bell and spigot, with elastomeric type gaskets. Glue joints will not be allowed. Rubber couplings shall be molded, one piece, neoprene with stainless steel bands (FERNCO Type 1056 or equivalent). Caulder or Caulder type, couplings will not be allowed.
- a continuous section of 14 gauge coated electrical wire shall be included in the trench with the sewer pipe in order to provide for quick and accurate line locates. The wire shall be provided at the District's expense and shall be inspected prior to back filling the trench.
- bedding for the pipe shall consist of pea gravel, sand, road base or selected fill as approved by the District. Should wet soil conditions exist, one and one-half (1 ½) inch washed rock may be required. The pipe will be covered with at least twelve (12) inches of the same required

material. The balance of the trench can be filled with other suitable material.

- eight (8) inch sewer pipe shall be installed at not less than .40 percent grade to meet the minimum slope requirements.
- ten (10) inch or larger sewer pipe shall be installed at not less than .20 percent grade to meet the minimum slope requirements.
- additional site work may be required to allow for safe future access to the line by District personnel and equipment. The District line superintendent shall instruct the installer of any requirements necessary.
- all excavations and trench work shall include adequate clean up of the grounds that have been disturbed. If an installer is working through an existing easement of the Districts, the disturbed area shall be returned to its approximate state, previous to the excavation. This may include, but not limited to: raking, reseeding, special ground cover (washed rock, road base, etc.) or re-paving.
- Special rules shall apply for any sewer mains that shall cross any bodies of water (i.e. ponds, lakes, rivers, creeks, etc.). Administrative review shall be necessary and the installer of the line shall be notified of any and all special requirements.

#### 7.40 Depth of Line

- Minimum depths of bury for a sanitary sewer main line shall be forty-eight (48) inches, where practical except by approval from the District.

#### 7.50 Manholes

An authorized representative of the District shall carefully review all manhole installations. Manholes can be significant sources of infiltration and blockages. Improperly installed manhole bases can prevent the use of equipment for maintenance and cleaning. Poorly designed manholes can create safety issues for District person-

nel. Therefore, the highest priority will be placed on the quality of installation of manholes. Several rules will be applicable to all manholes. Other construction requirements are exclusive to each type of manhole and they will be defined through exhibits.

7.51 Construction Requirements - General

- manholes installed by contractors shall be inspected by the District prior to and after the forming and pouring of manhole bases.
- finished manholes shall be grouted inside and out.
- manholes for eight (8) inch sewer pipe shall be four (4) feet in diameter.
- manholes for ten (10) inch and larger sewer pipe shall be five (5) feet in diameter.
- the length from the top of a coned manhole/ flat top section to the manhole lid shall not exceed thirteen (13) inches in height.
- manhole bases shall extend six (6) inches under the sewer pipe and three (3) inches over the sewer pipe.

7.52 Standard Manhole Construction

- Exhibits in Appendix.

7.53 Drop Manhole Construction

- Exhibits in Appendix.

7.54 Flat Top Manholes

- Exhibits in Appendix.

7.60 Stub Outs

The District will require each individual lot, to be serviced by the new sewer main, to have a stub out connection from the sewer main installed at the time of con-

struction of the main line. The stub out shall be a minimum of 10 feet and extended out horizontally of any asphalt that may be included in the development. The stub out shall extend to the property line of the lot that it shall service, unless otherwise approved by the Directors of the District. Stub outs shall be required to meet the District standards for sewer service lines and shall end with a bell connection.

#### 7.70 Required Inspections

The District may require, at its discretion, any one or combination of two or more of the following methods to insure the quality of the line installation that is being performed. The party to whom the permit is issued or by whom inspection is requested shall furnish the responsibility (equipment, material and labor) necessary for inspection or tests.

- visual inspection of all pipe, joints and manholes by District personnel or a District approved inspector prior to back filling the trench.
- a video recording of the line shall be performed by a closed circuit color television that shall record the inside of the line and manholes. District personnel shall review the tape recording and if requested, a representative of the party to whom the permit is issued.
- a water test, as per Section 318(b)(3) of the Uniform Plumbing Code book shall be administered.
- an air test, as per Section 318(b)(4) of the Uniform Plumbing Code book shall be administered.

All sections of the collection system that fail to pass any of the above inspections or tests, shall be brought into compliance by the person or company who performed the installation at that time.

## 7.80 Construction Guarantee

After completion of the installation of the sewer main line and passing all inspections and/ or tests, the installer of the line shall provide a one year guarantee to the party to whom the permit was issued and to the Estes Park Sanitation District. The District may perform, at their expense additional tests on the line during this time period to insure the quality and integrity of the line. Should any deficiencies be discovered, the company issuing the guarantee shall be notified in writing of the problems. Thirty (30) days shall be allowed for the deficiency to be corrected, unless otherwise approved by the Directors of the District.

## 7.90 Documentation

As final steps for the acceptance of ownership and maintenance of the sewer line by the District, the following requirements legal documents must be executed.

- written easements for the sewer line shall be provided for the future maintenance and repair of the line. The minimum easement shall be fifteen (15) feet in width (7 ½ feet on either side of the centerline of the pipe). This easement may appear on the recorded development plat or may be a separate document defining the path of the line through the property. All parties shall sign it. Plat easements shall have the same restrictions, rights and agreements that are in place for separate document easements.
- two copies of the final recorded plat map shall be given to the District.
- construction as-builts shall be provided.
- a warranty deed from the party to whom the permit was issued shall be signed by all parties involved, conveyed to the District and recorded.

## 8.00 MAINTENANCE REQUIREMENTS

### 8.10 Sewer Service Lines

It shall be the responsibility of the tap holder to ensure that sewer service lines are in good condition. Sewer service lines are for the sole purpose of collecting domestic wastewater from the building(s) or residence(s) that it serves. Lines that leak, allow infiltration or back up from poor construction or deteriorating condition may be required to be cleaned, repaired or replaced in their entirety by the District. All expenses associated with these requirements will be the responsibility of the tap holder. The District shall provide written notification of the steps required to the tap holder. A reasonable period of time will be allowed for the required action to be performed.

The District reserves the right to perform steps necessary to ensure the good working condition of any sewer service line connected to the District's collection system. These steps may include, but not be limited to:

- visual inspections of the line.
- visual inspection of the building and all fixtures connected to sewer service line.
- installation of clean outs on lines where none exist.
- the plugging of flow to line to see if infiltration exists.
- sampling of flow from the service line to determine it's content.
- televising the line by use of cameras and equipment.
- smoke testing to find sources of infiltration.
- disconnecting illegal connects to the line.

### 8.20 Sewer Main Lines

The District reserves the right to perform steps necessary to maintain the good working condition of any and all of the District's main collection lines. These steps shall include, but not be limited to:

- visual inspections of the line or manholes
- periodic cleaning by use of sewer equipment
- root cutting
- re-grouting
- televising the line by use of cameras and equipment
- smoke testing to find sources of infiltration
- spot repairs
- replacement of the line
- enlargement of the line
- installation of additional manholes
- replacement of manholes

All costs associated with maintenance of District sewer main lines will be the responsibility of the District.

## 9.00 SPECIAL APPLICATIONS AND REVIEWS

Unless otherwise determined by the Directors of the District, all properties within four hundred (400) feet of a District sewer main line will be required to take steps necessary to connect to the wastewater collection system of the District. In addition, the District may require special requirements.

### 9.10 Board of Director Comments

The Directors shall review all plans for development or for construction within the boundaries of the District. Comments given by the Directors shall be viewed as requirements for connection to the Districts collection system. These comments

may be directed to the Town of Estes Planning Commission, Larimer County Planning Commission or individual building permit requirements. Action on the comments will be required prior to any transmission of flow to the District's collection system.

## 9.20 Interceptors

Interceptors will be required by the District, when in the judgment of the District Representative, they are necessary for the proper handling of liquid wastes containing fats, oils and grease (FOG), flammable wastes, sand, soils, acids or alkaline substances or other ingredients harmful to the building drainage system or the District's collection and treatment facilities.

- sand interceptors will be required for all commercial applications where the introduction of oil, grease, soil and dirt may occur. The administrative authority on case will review all sizing requirements. All sand interceptors shall be maintained in efficient operating condition by periodic removal of the accumulated waste material. No such waste material shall be introduced into the drainage or collection system. Records of cleaning shall be kept by the owner of the establishment using the sand interceptor and made available to the District for review.
- external grease interceptors will be required of commercial establishments where food is prepared or processed, including but not limited to; restaurants, cafes, lunch counters, cafeterias, bars, bakeries, sandwich shops, meat cutting businesses and other similar establishments. The administrative authority on case will review all sizing requirements. All grease interceptors shall be maintained in efficient operating condition by periodic removal of the accumulated grease. Introduction of grease shall not be allowed into the drainage or collection system of the District. Records of cleaning shall be kept by the owner of the establishment using the grease interceptor and made available

to the District for review. Affected commercial establishments can ask for Special Review by the Board of Directors. Rules and regulations for grease interceptors are available upon request.

### 9.30 Non-Gravity Flow Applications

#### 9.31 Pump Stations

Pump or Lift Stations shall be required of developments desirous of sewer service, where gravity flow is not possible. All development plans that include lift stations shall be reviewed by the District on an individual basis for sizing and location, along with plans for sewer main installations. The District will assume ownership of development pump stations that meet the requirements of the District. A service fee will be charged all users of pump stations that have been installed by developments and then deeded to the District for ownership and maintenance.

Multi-Family Developments that require sewer service where gravity flow is not available shall be required to install adequate size lift stations to serve the facility. Ownership and maintenance of the facility will remain with the development unless otherwise approved by the Directors of the District. A service fee will be charged all users of pump stations that have been installed by developments and then accepted by the District for ownership and maintenance.

#### 9.32 Grinder Pumps

Individual residences that are within four hundred (400) feet of a sewer main line, but unable to pursue gravity flow shall be required to install an approved grinder pump facility to pump the flow of wastewater to the Districts sewer main line. Ownership and maintenance of the facility shall remain with the individual residence.

9.40 Pre-Treatment

The discharge of non-domestic wastewater to the collection system of the District shall not be allowed. Installation of pre-treatment facilities on entities that discharge other than domestic wastewater will be required.

10.00 COMPLIANCE

10.10 Failure to Follow Regulations

Violation of these rules and regulations shall constitute sufficient grounds for the removal of the installer of the sewer lines from the list of acceptable installers approved by the District. No tap connects will be allowed until the violations have been properly corrected. Failure to follow all rules associated with maintenance or special review requirements shall constitute sufficient grounds for disconnect of private party lines from the District's collection system. All charges associated with disconnection and reconnection shall be the responsibility of the tap holder.

10.20 Abandoned or Disconnected Taps

Any building, commercial or residential, once connected to the District's collection system shall be required to continue to pay all fees associated with users of the District in order to maintain their tap. This requirement recognizes the many expenses associated with District operation beyond wastewater treatment. The owner of any building considering disconnection such as a demolition may apply to the board of directors for a tap certificate equal to the value of the existing fixture units associated with the building. User fees will not be applicable to tap certificates. However certificates shall only be valid for a period of five years. Buildings or property adversely affected by natural disasters may also apply for tap certificates. A tap certificate is transferable only through board of director approval prior to transfer.

11.00

EXHIBITS

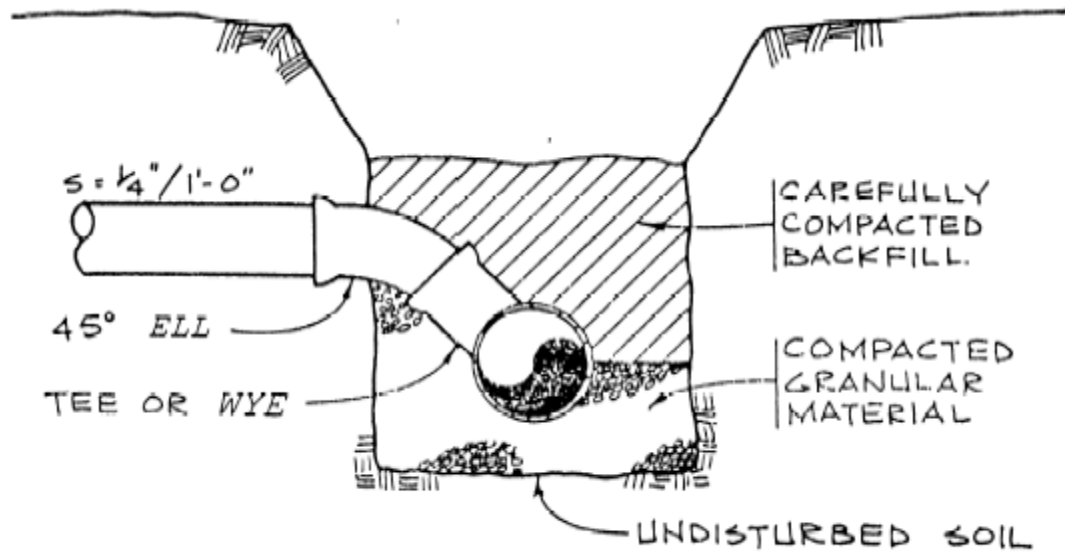

Service Line Connection Details



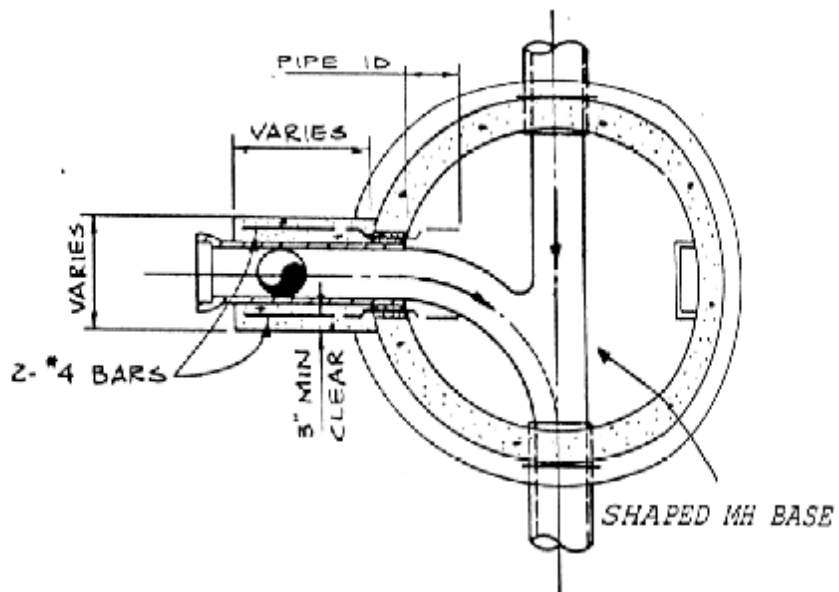
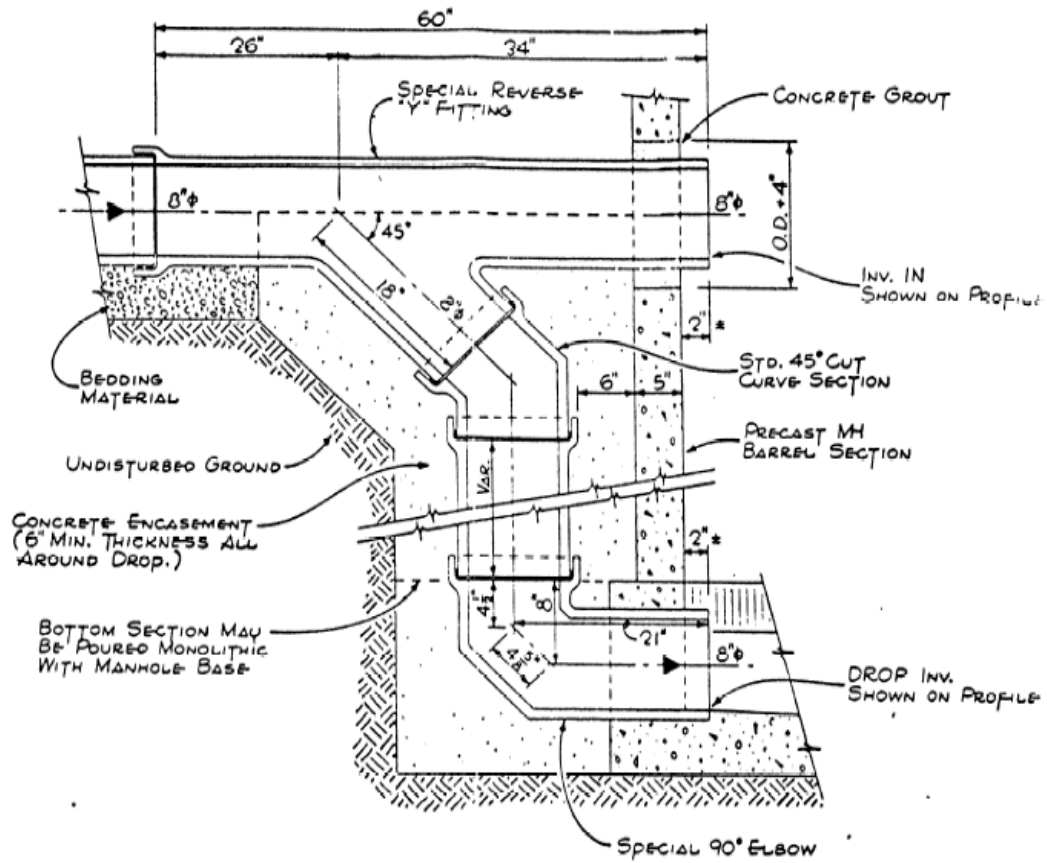

DROP MANHOLE AND BASE DIAGRAMS

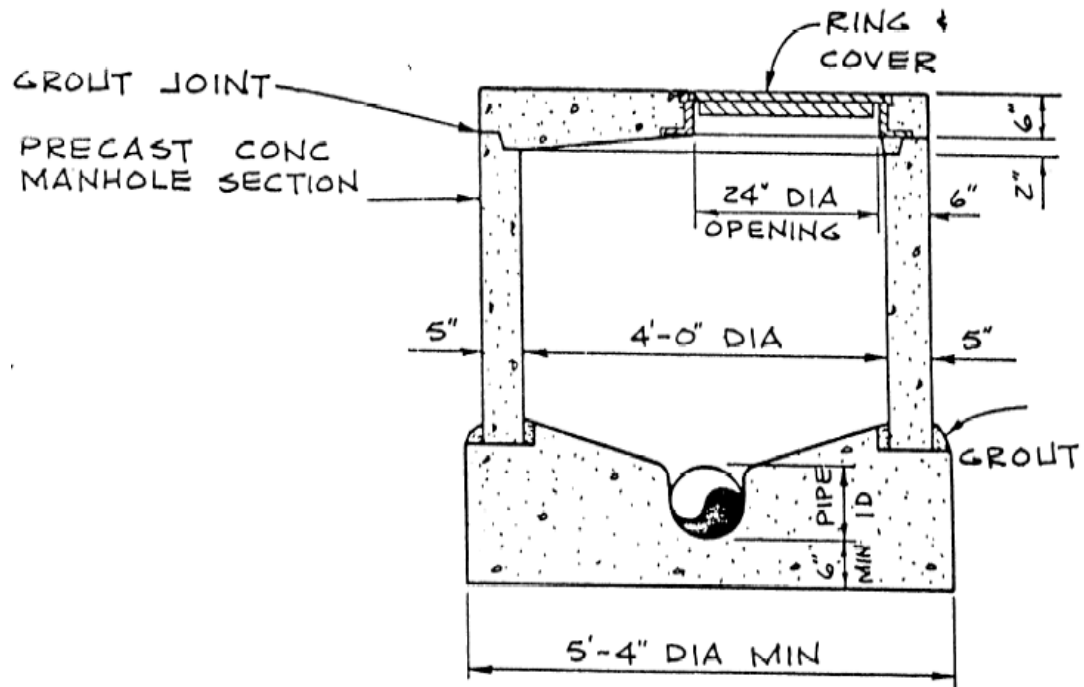

Type A = 8 inch pipe  
 Type B = 10 inch pipe or larger

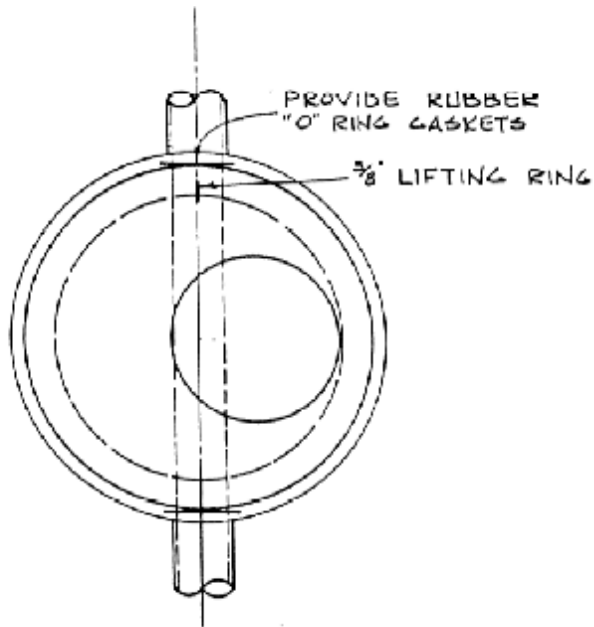

## FLAT TOP MANHOLE AND BASE DIAGRAMS

## EASEMENT AGREEMENT (EXAMPLE)

This agreement, made this \_\_\_\_\_ day of \_\_\_\_\_, \_\_\_\_\_,

between \_\_\_\_\_, as

GRANTOR(S); and \_\_\_\_\_ as

GRANTEE(S), is as follows: FOR VALUABLE CONSIDERATION, the receipt and sufficiency whereof is acknowledged the GRANTOR, owners of the real property described as:

---

(Parcel # \_\_\_\_\_, Schedule # \_\_\_\_\_) and their successors and assigns, DO HEREBY GRANT unto the GRANTEE and their successors and assigns, a permanent easement for a existing sewer pipe, with the right to construct, maintain, inspect, operate, repair, replace and remove such sewer pipe. Said sewer pipe shall be for the transmission of sewage under and through a permanent easement described upon Exhibit A which is attached hereto and incorporated herein by this reference.

The GRANTOR(S) hereby warrants that they are the owner in fee simple of the above said property, and are authorized to grant this easement. The GRANTOR(S) hereby grants unto the GRANTEE, for the purposes herein set forth, the right of access to said easement and the right of ingress and egress on and over the easement described in Exhibit A for maintenance and repair purposes. The following conditions for this easement shall be in place.

1) The sewer line shall run within the above-mentioned permanent easement. Upon completion of any repair or maintenance work, the GRANTEE, at their expense, shall restore the surface of such property, as is affected, to substantially the same condition as existed prior to such work.

2) GRANTOR(S) reserve(s) the right to use and enjoy such described property so long as such use and enjoyment does not interfere with the rights herein granted to the GRANTEE. GRANTOR(S) specifically agree(s) not to build, create, or construct any obstructions or struc-

tures over or within said easement, plant trees or impound any water thereon, and not permit the same to be done by others without the written consent of the GRANTEE.

3) The GRANTEE agrees to recognize that fences, concrete sidewalks, non-concrete roads or parking areas, and similar uses are not deemed to be obstructions or structures as long as they allow for access to said sewer pipe for the rights of the GRANTEE as stated previously.

4) The terms, conditions, provisions of this easement grant shall extend to and be binding upon the heirs, personal representatives, successors and assigns of the parties hereto.

IN WITNESS WHEREOF, THE GRANTOR AND GRANTEE HAVE EXECUTED THIS EASEMENT AGREEMENT THE DAY AND YEAR FIRST ABOVE WRITTEN.

\_\_\_\_\_  
Grantor,

\_\_\_\_\_  
Grantee,

\_\_\_\_\_  
Grantor,

\_\_\_\_\_  
Grantee,

State of \_\_\_\_\_ )

)

ss.

County of \_\_\_\_\_ )

The foregoing instrument was acknowledged before me this \_\_\_\_\_ day  
of \_\_\_\_\_, \_\_\_\_\_, by: \_\_\_\_\_

Witness my hand and official seal.

My commission expires: \_\_\_\_\_

\_\_\_\_\_  
Notary Public

**SHARED SEWER SERVICE LINE AGREEMENT**

THIS SHARED SEWER SERVICE LINE AGREEMENT is made between \_\_\_\_\_

\_\_\_\_\_ owner(s) of

the real property described as: \_\_\_\_\_

(Parcel # \_\_\_\_\_, Schedule # \_\_\_\_\_) and their successors and assigns;

AND

\_\_\_\_\_ owner(s) of

the real property described as: \_\_\_\_\_

(Parcel # \_\_\_\_\_, Schedule # \_\_\_\_\_) and their successors and assigns;

Whereas the above mentioned parties wish to share a sewer service line that connects the above mentioned properties to the main sewer trunk line in (list street address) \_\_\_\_\_

\_\_\_\_\_, Estes Park, owned and maintained by the Estes Park Sanitation District; the following agreements are made:

1. Ownership Shall Be Mutual. From the point where the service line connects to the main line of the Estes Park Sanitation District to the point where the line separates into two lines to serve each party's place of residence, ownership of this line shall be considered mutual.

2. Shared Maintenance. Maintenance of the section of the sewer line that is shared shall be borne equally by both parties.

3. Sewer User Fee Charges To Be Billed Separately. The parties request separate billing for fees that are required and payable to the Estes Park Sanitation District. Should one of the parties to this agreement fall into arrears on these user fee charges, disconnection shall occur at a point that will not affect the service of the other party and all charges associated with disconnecting sewer service and then reconnecting sewer service shall be borne by that party

that is disconnected. The Board of Directors of the Estes Park Sanitation District for sewer shut off sets charges.

4. Running of Benefits and Burdens. All provisions of this instrument, including the benefits and burdens, run with the land and are binding upon the heirs, assigns, successors, tenants and personal representatives of the parties hereto.

IN WITNESS WHEREOF, the parties herein have signed this SHARED SEWER SERVICE LINE AGREEMENT.

\_\_\_\_\_  
Property Address

\_\_\_\_\_  
Property Address

\_\_\_\_\_  
Owner

\_\_\_\_\_  
Owner

\_\_\_\_\_  
Owner

\_\_\_\_\_  
Owner

State of \_\_\_\_\_ )

)

ss.

County of \_\_\_\_\_ )

The foregoing instrument was acknowledged before me this \_\_\_\_\_ day of

\_\_\_\_\_, \_\_\_\_\_ by \_\_\_\_\_

Witness my hand and official seal.

My commission expires: \_\_\_\_\_

\_\_\_\_\_

Notary Public